

DIMENSIONS

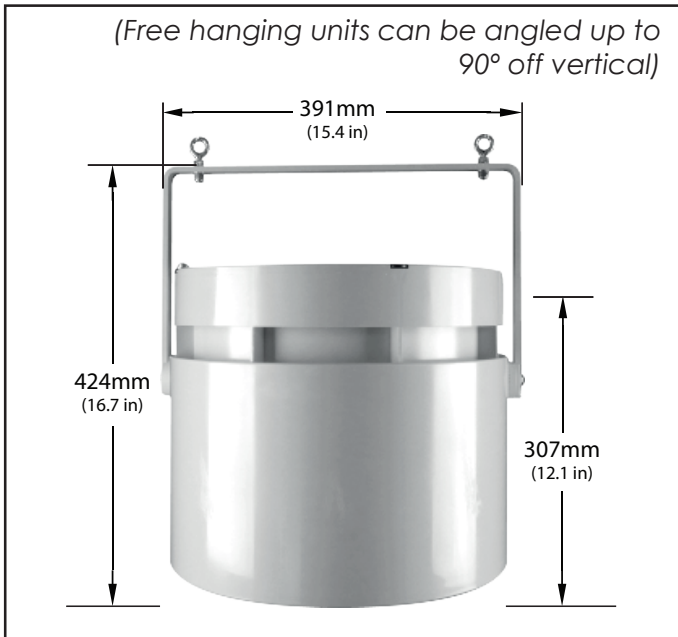

PROPERTIES

UNIT SIZE	STANDARD	
	Weight:	6 kgs (13 lbs)
	Height to Rim:	307 mm (12.1 in)
	Total Height:	424 mm (16.7 in)
	Diameter:	391 mm (15.4 in)

MOTOR	230V	
	Watts* @ 50 htz:	77
	RPM* @ 50 htz:	1,371
	L/S* @ 50 htz: (m3/hr):	513 (1,850)
	Centre Line Velocity ¹ :	1.02 m/s (@9 Metres)
	AMPS* @ 50 htz:	0.30
	Thrust*:	3.00 Newtons

*Motor data provided by motor manufacturer and is subject to change at anytime
¹Velocity profile tested in situ

PUREAIR+ NPBI ONYX SERIES RANGE - MODEL PS-4

DESCRIPTION

- Air purification and odour control destratification and airflow circulation fan.
- Features integrated Needlepoint Bipolar Ionization (NPBI) System.
- Emits both positive (H+) and negative (O₂⁻) ions.
- Ions surround harmful pathogens and react as Hydroxyl (OH) radicals. This process removes hydrogen from the cell walls of microbes, inactivating harmful pathogens at a cellular level.

FEATURES

- 99.9%+ effective at neutralising COVID19 (SARS-CoV-2).
- Inactivates surface germs, bacteria & viruses by 99%+.
- Inactivates airborne germs, bacteria & viruses by 99%+.
- Reduces odours by 99%+.
- Reduces VOCs, gases & vapours by 99%+.
- Energy Savings of up to 40% by destratifying and reducing outdoor air intake by up to 75%.
- Reduces pressure loss by keeping HVAC coils clean without expensive UV system.
- Particle reduction and smoke control.
- Balances internal building temperatures.
- No maintenance required.

COVERAGES	AIRFLOW	
	Ceiling Height:	Up to 13m (42 ft)
	Nozzle Height:	Up to 12m (39 ft)
	Diameter:	Up to 12m (39 ft)
	Floor area:	Up to 182m ² (1,959 ft ²)

*Coverages can vary dependent upon environment and load.



MOTOR

- Single phase, shaded pole, single speed variable with optional speed control, axial motor.
- Sealed bearings, no lubrication required.

NPBI SYSTEM

- Self-cleaning, maintenance free Needlepoint Bipolar Ionization air and surface purification system.
- Ozone free system.

PROPERTIES

VELOCITY PROFILE

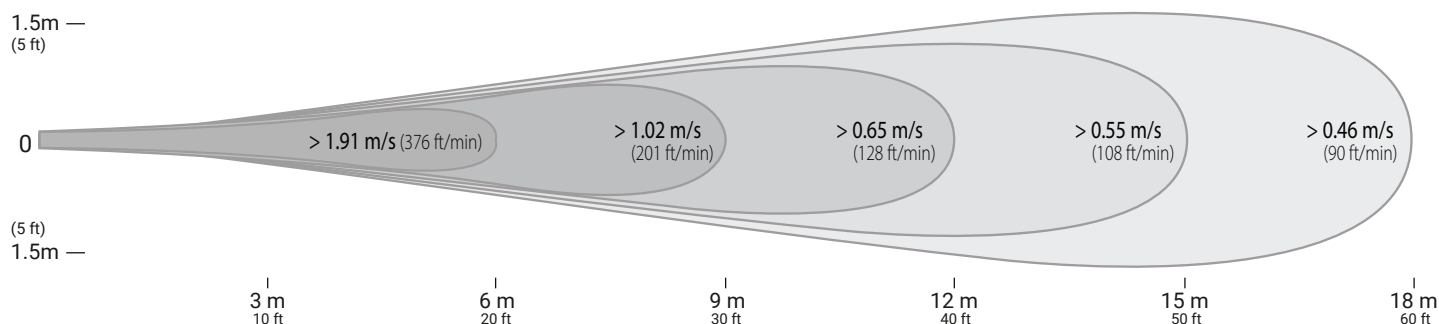

HOUSING & COMPONENTS

- ABS Resin - Inc. internal fixed blade stator.
- 5VA flame resistance rating.

OPERATING TEMPERATURES

- Operating Temp = -25°C (-13°F) to 70°C (158°F)
- Thermal shut off = 110°C (230°F)
- Reset = 90°C (195°F)

NOISE LEVEL

- 13 Metres = 0 - 40 dB(A)

COLOUR

- White as standard.
- Can be tailor painted to your colour specifications.

ACCESSORIES & OPTIONS

- Speed Controls - On/off speed controls allow for variable output from Airius unit. 1 AMP and 5 AMP controls available.

OPERATION

- Designed to operate 24 hours-a-day, 7 days-a-week to protect against airborne mould, bacteria, viruses, odours and VOCs and save heating & cooling costs.

MAINTENANCE

- No maintenance required.
- If the NPBI unit fails, contact manufacturer.

WARRANTY

- 5 years parts and workmanship from shipping date on fan unit.
- 120 day money back guarantee - UK only (T's & C's apply).

SAFETY PRECAUTIONS

- General safety measures and precautions should be followed when working with any electrical device.
- No additional safety measures are necessary for working with either the fan or NPBI system.

PLACEMENT

PREPARATION

- Install electrical circuit(s) and outlet(s) in accordance with national and local electric codes
- Outlets should generally be mounted vertically unless a "twist/locking" type is being used
- Wall switch may be installed in circuit to disable power and prevent electrical hazards when servicing
- Confirm electrical continuity of Airius unit on the ground before permanently mounting in the ceiling

INSTALLATION

- Hang vertically as high in the ceiling as possible. Typically 300mm (12") - 450mm (18") from the roof deck to intake
- The Airius unit performs best when air column from the nozzle is unimpeded to the floor
- Use professionally installed hardware, capable of supporting a minimum of five times the weight
- Hardware to hang the unit includes but is not restricted to: Hooks, chains, cables, carabiners, bridle rings, beam clamps and bolts
- Density of the placement is directly related to the effectiveness, performance and savings
- Mount out of reach from people and animals
- Floor plans, mezzanines, office locations, machinery, people placement, plumbing, lighting, duct work, electrical systems, natural light/air systems, cranes, doors, windows, ventilation and fire suppression systems are all factors in properly locating the Airius system within the ceiling

OPERATION

- Designed to operate 24 hours-a-day, 7 days-a-week to maintain thermal equalization/humidity equalization
- Use optional speed control to fine tune RPM if needed

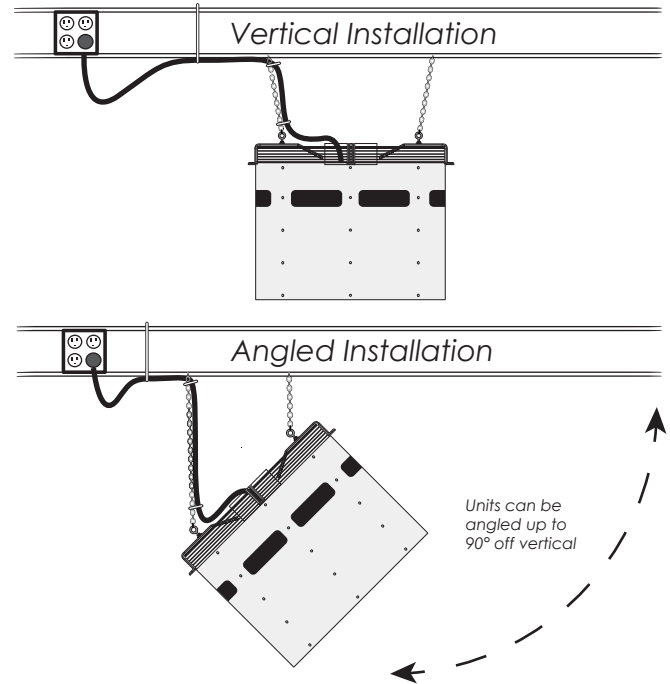

MAINTENANCE

- Frequency of cleaning will vary by application and environment
- You may clean the plastic housing with a damp warm cloth, using mild household detergents
- Do not use petroleum products, thinners or solvents to clean any part of the Airius unit
- If the Airius unit fails, contact manufacturer